

research report

Fire Resistance Ratings of Load Bearing Steel Stud Walls With Gypsum Wallboard Protection

RESEARCH REPORT RP81-1

**1981
REVISION 2007**



American Iron and Steel Institute



Steel Framing Alliance™

Steel. The Better Builder.

DISCLAIMER

The material contained herein has been developed by researchers based on their research findings and is for general information only. The information in it should not be used without first securing competent advice with respect to its suitability for any given application. The publication of the information is not intended as a representation or warranty on the part of the American Iron and Steel Institute, Steel Framing Alliance, or of any other person named herein, that the information is suitable for any general or particular use or of freedom from infringement of any patent or patents. Anyone making use of the information assumes all liability arising from such use.

PREFACE

This report presents the results of a two-phase study, which included nine full-scale fire tests conducted at Underwriters Laboratory, Inc. (UL), small scale tests at the Research Laboratory of the United States Steel Corp. (USS) to determine the effects of temperature on material properties, and further work by the USS Research Laboratory to develop additional information for refining and substantiating the aforementioned data for temperatures up to approximately 1800 degrees F (982 degrees C).

The findings provided some of the back-up data for the fire-resistance ratings given in UL Design No. U425.

Research Team
Steel Framing Alliance

Fire Resistance Ratings of Load Bearing Steel Stud Walls

With Gypsum Wallboard Protection with or without cavity insulation

Building Code Provisions

Building codes frequently require load-bearing walls to have a fire-resistance rating that is based on fire tests conducted in accordance with a specification of the American Society of Testing & Materials (ASTM) title ASTM E119, *Standard Methods of Fire Tests of Building Construction and Materials*.

In the case of load-bearing walls, this test stipulates that they must: a) withstand fire exposure, under a specified loading, without structural collapse, thereby preventing flame passage through the wall, and b) prevent intra-wall transmission of heat that will ignite combustible materials on the unexposed side of the wall for which the indication of failure is defined as a 250 degrees F (139 degrees C) average temperature rise on the unexposed surface or 325 degrees F (181 degrees C) temperature rise at any one point. The fire exposure is followed by a fire and hose-stream test that is designed to evaluate the wall's resistance to the passage of the hose stream through the wall.

Research Program

The American Iron and Steel Institute (AISI) sponsored a research program that sought to develop an analytical method that would make it possible to predict the structural behavior of cold-formed sheet-steel studs in load-bearing walls under the conditions set forth in the ASTM E119 Standard Fire Test. This program called for full-scale fire tests designed to provide data on the effects of insulation, wallboard thickness, and loading on the fire-resistance ratings.

The entire study was conducted along two lines:

Phase 1 consisted of seven full-scale fire tests conducted at Underwriters Laboratory, Inc. (UL). These investigations provided basic data as called for in the program. While this work was being carried out at UL, the Research Laboratory of the United States Steel Corp. (USS) was conducting small-scale tests on steel studs, to determine the effects of temperature on *yield strength* (F_y), *effective cross-sectional strength* (Q), and the *modules of elasticity* (E).

Phase II involved further work by the USS Research Laboratory to develop additional information for refining and substantiating the aforementioned data for temperatures up to approximately 1800 degrees F (982 degrees C). In addition, during this second Phase, two other full-scale fire tests were run at UL. These included increased instrumentation to measure: a) the wall loading prior to and during the test, B) wall deflection at the point of structural failure, and temperature measurements of each steel stud.

Construction of Fire-Tested Assemblies

The load-bearing wall assemblies were constructed in two ways – with and without insulation in the concealed space between cold-formed sheet steel studs spaced 24 inches o.c. Tests were run on studs faced with 1/2 inch or 5/8 inch thick Type X gypsum wallboard in one, two or three layers. Design of the steel studs followed the recommendations of the AISI *Specification for the Design of Cold-Formed Steel Structural Members*, 1968 Edition, assuming steel studs were fully braced laterally by the gypsum wallboard.

Fire-resistance ratings, construction and material details are given in UL *Fire Resistance Directory* as Design No. U425. (Fig. 1) The ratings assigned to this Design are based on data from this test program along with data from three tests that had been carried out prior to the present work.

**UL Fire Resistance Directory
Design No. U425**

Interior Walls – Wallboard Protection Both Sides of Wall

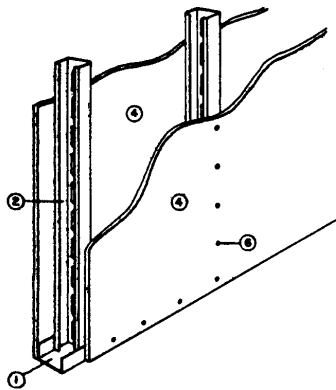

Rating	Number of Layers and Thickness of Boards in Each Layer	Percent of Design Load
45 min	*1 layer, ½ in. thick	100
1 hr	*1 layer, 5/8 in. thick	100
1 ½ hour	*2 layers, ½ in. thick	100
2 hr	*2 layers, 5/8 in. thick or *3 layers, ½ in. thick	80 100

*Ratings applicable to assemblies serving as exterior walls where Classified fire resistive gypsum sheathing type wallboard is substituted on the exterior face.

Exterior Walls – Wallboard Protection on Interior Side of Wall

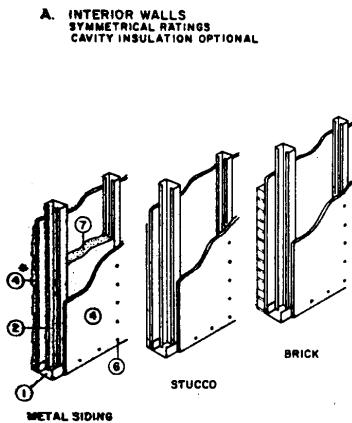

Rating	Number of Layers and Thickness of Boards in Each Layer	Percent of Design Load
45 min	1 layer, 5/8 in. thick	100
1 hr	2 layers, ½ in. thick	100
1 ½ hour	2 layers, 5/8 in. thick	100
2 hr	3 layers, ½ in. thick	100

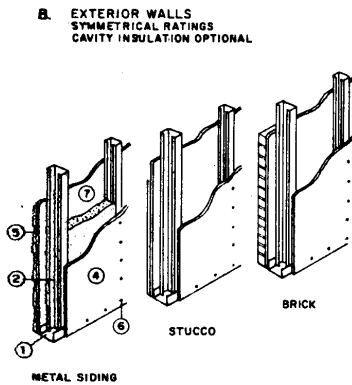

1. Steel Floor and Ceiling Tracks – Top and bottom tracks of wall assemblies shall consist of steel members, min. No. 20 GSG (0.036 in. thick) galv. steel or No. 20 MSG (0.033 in. thick) primed steel, that provide a sound structural connection between studs, and to adjacent assemblies such as floor, ceiling and/or other walls. Attached to floor and ceiling assemblies with steel fasteners spaced not greater than 24-in. o.c.

2. Steel Studs – Corrosion-protected steel studs, min. 3 ½ in. wide, min. No. 20 GSG (0.036 in. thick) galv. steel or No. 20 MSG (0.033 in. thick) primed steel, cold-formed, shall be designed in accordance with the current edition of the *Specification for the Design of Cold-Formed Steel Structural Members* by the American Iron and Steel Institute. All design details enhancing the structural integrity of the wall assembly, including the axial design load of the studs, shall be as specified by the steel stud designer and/or producer, and shall meet the requirements of all applicable local code agencies. The max. stud spacing of wall assemblies shall not exceed 24 in. Studs attached to floor and ceiling tracks with ½ in. long Type S-12 pan head, self-drilling, self-tapping steel screws on both sides of studs.

3. Lateral Support Members (Not shown) – Where required for lateral support of studs, support may be provided by means of steel straps, channels or other similar means as specified in the design of a particular steel stud wall system.

4. *Wallboard, Gypsum – Any gypsum wallboard bearing the ULI Classification Marking as to Fire Resistance. Applied vertically with joints between layers staggered. Outer layer of three-layer construction may be applied horizontally. The thickness and number of layers and percent of design load for the 45 min, 1 hr, 1 ½ hr and 2 hr ratings are as shown above. See Wallboard Gypsum (CKNX) Category for names of Classified Companies.

5. Gypsum Sheathing and Exterior Facings – For exterior walls, single layer of ½ in thick exterior regular gypsum sheathing applied vertically and attached to studs and runner tracks with 1 in long Type S-12 bugle head screws spaced 12 in o.c. along studs and tracks. Exterior facings consisting of aluminum siding, steel siding, brick veneer, or stucco attached to studs over gypsum sheathing and meeting the requirements of the local code agencies. When a min. 3 ¾ in thick brick veneer facing is used, the Exterior Wall Rating is applicable with exposure on either face side. Brick veneer wall attached

to studs with corrugated metal wall ties attached to each stud with steel screws, not more than each sixth course of brick.

6. Fasteners – Screws used to attach wallboards to studs: self-tapping bugle head sheet steel type, spaced 12 in o.c. First layer Type S-12 by 1 in long; second layer Type S-12 by 1 3/8 in long; third layer Type S-12 by 1 7/8 in long.

7. *Batts and Blankets – Placed in stud cavities of all exterior walls. May or may not be used in interior walls. Any glass fiber or mineral wool batt material bearing the UL Classification Marking as to Fire Resistance, of a thickness to completely fill stud cavity. See Batts and Blankets (BZJZ) Category for names of Classified Companies.

8. Joint Tape and Compound – Vinyl or casein, dry or premixed joint compound applied in two coats to joints and screwheads of outer layer. Perforated paper tape, 2 in wide, embedded in first layer of compound over all joints.

*Bearing the UL Classification Marking

Fig.1 Details A,B & C. Drawings and accompanying description of these three assemblies are adapted from Design No. U425 as given in the UL Fire Resistance Directory

Conclusion

Figure 2 is a representation of the *load-ratio vs. failure-time* curves that provided some of the back-up data for the fire-resistance ratings given in UL Design No. U425. Here (Fig. 2), the load-ratio (P_T/P) is the ratio of the stud failure load at elevated (test) temperature, P_T , to that at room temperature, P . The horizontal line, a load-ratio of 12/23, represents the inverse of the safety factor used in room-temperature design of studs. The intersection points, on the horizontal line, made by the failure-time curves, represent the predicted fire-test failure time if the applied load of 100% of the design load at room temperature. Thus, dashed lines are used for the curves above this line because the allowable design loads at room temperature would be exceeded in this region. The vertical scale on the right is the ratio of the *allowable fire-test load* to the *allowable room-temperature load* calculated in accordance with the *AISI Specification for the Design of Cold-Formed Steel Structural Members*, 1968 Edition.

In using the fire-resistance ratings assigned to UL Design No. U425 the following should be noted:

- ❑ Loads are expressed as a percentage of the maximum load specified for steel studs by the given manufacturer.
- ❑ Steel studs must be designed in conformity with *AISI Specification for the Design of Cold-Formed Steel Structural Members* (current edition).
- ❑ Insulation in the wall cavity does not affect the assigned fire-resistance rating of interior walls (Fig. 1, Detail A). UL fire tests demonstrated that a wall assembly, *tested without insulation*, does not have its structural integrity reduced nor are premature hot spots on the unexposed side of the wall produced.
- ❑ Ratings for interior walls are equally applicable to exterior walls (Fig. 1, Detail B). UL classified fire-resistive exterior gypsum wallboard sheathing may be substituted for gypsum wallboard on the exterior wall face. Ratings for such exterior walls are applicable for either wall face.
- ❑ If UL classified fire-resistive, water-resistant gypsum wallboard is substituted for the non-water-resistant type on interior locations, e.g. bathrooms, the assigned rating remains unchanged.
- ❑ For exterior walls having the specified type of brick veneer, the fire-resistance rating applies to either side of the wall (Fig. 1, Detail C).
- ❑ Fire-resistive ratings for *load-bearing walls* can be applied to *non-load-bearing walls*.
- ❑ Exterior wall facings, if different from those described in the UL Directory, may be acceptable if they are secured to the steel framing in a manner acceptable to the authority with jurisdiction (Fig. 1, Detail B or C).

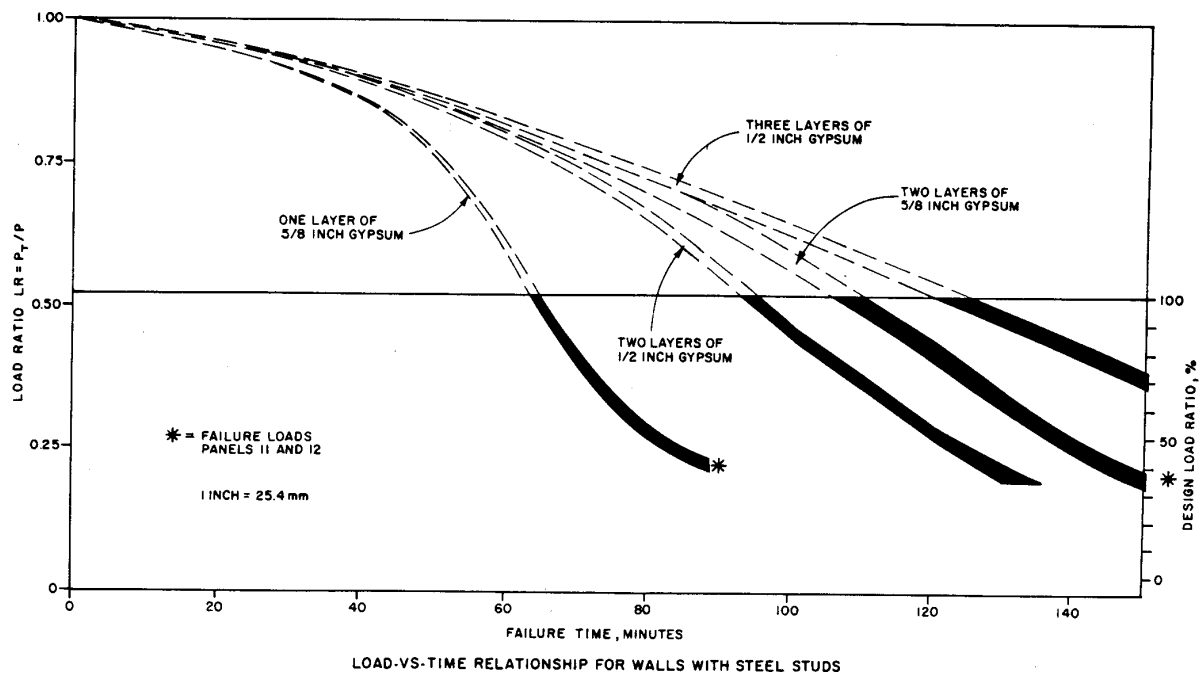

Figure 2. Curves of the load vs. time relationship for steel stud walls with various gypsum wallboard protections. Adapted from paper by K.H. Klippstein³

References

1. "Standard Methods of Fire Tests of Building Construction and Materials," American Society for Testing and Materials, *ASTM E119-79*.
 2. "Specification for the Design of Cold-Formed Steel Structural Members," American Iron and Steel Institute, 1968 Edition.
 3. Klippstein, K.H., "Behavior of Cold-Formed Steel Studs in Fire Tests," Proceeding, Fifth Specialty Conference, University of Missouri-Rolla, November 1980.
-

Data, specifications, architectural/engineering information and drawings presented in this publication have been delineated in accordance with recognized professional principles and practices, and are for general information only. Suggested procedures and products should not, therefore, be used without first securing competent advice with respect to the suitability for any given application.

The publication of material contained herein is not intended as a warranty on the part of the American Iron and Steel Institute-or any person named herein-that these data are suitable for any general or particular use, or of freedom from infringement of any patent or patents. Any use of these data or suggested practices can only be made with the understanding that the American Iron and Steel Institute makes no warranty of any kind respecting such use and the user assumes all liability arising therefrom.

This publication was prepared by the Subcommittee on Fire Technology of the Committee on Construction Codes and Standards



American Iron and Steel Institute

1101 17th Street, NW, Suite 1300
Washington, DC 20036-4700

Copyright 1981 by American Iron and Steel Institute



American Iron and Steel Institute

1140 Connecticut Avenue, NW
Suite 705
Washington, DC 20036
www.steel.org



Steel Framing Alliance™

Steel. The Better Builder.

1201 15th Street, NW
Suite 320
Washington, DC 20005
www.steel framing.org

